



ACCURATE
SCREW MACHINE

LOW-PROFILE SPRING-LOADED CAPTIVE PANEL FASTENERS

Adding to our already extensive product line, Accurate Screw Machine (ASM) now offers **Low-Profile, Spring-Loaded Captive Panel Fasteners!**

These Spring-Loaded Captive Panel Fasteners will secure your panel cover ensuring no more lost screws, and they are manufactured to the same high quality standard you've come to expect from ASM. These fasteners are RoHS compliant and available in thread ranges from 440 through 1/4-20 (standard) or M3, M4, M5 and M6 (metric). Best of all, they are available in small or large quantities, and your order is always in stock and available for immediate turnaround.

Contact us today for more information about ASM's new Low-Profile Spring-Loaded Captive Panel Fasteners or any of our other fastener lines, or to request a copy of our printed full line catalog.

	Material	Finish
Retainer	Carbon Steel	Bright Nickel over Copper Flash
Screw	Carbon Steel	Bright Nickel over Copper Flash
Spring	300 Series Stainless Steel	Self-Finish

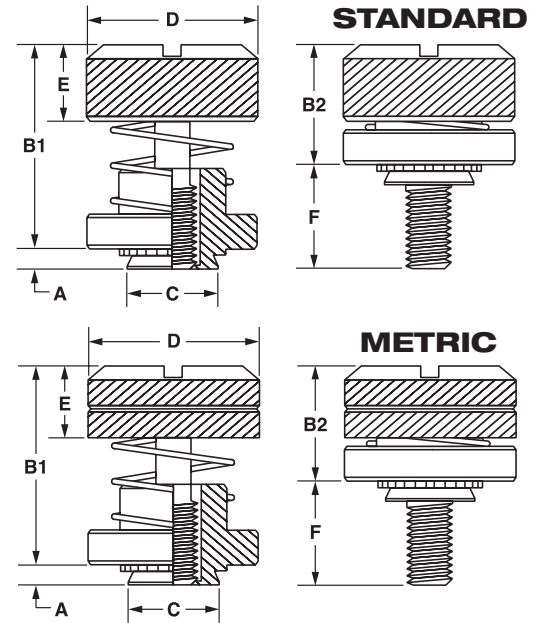

NOTE: The line on the metric knurl is to differentiate between metric and unified thread size.

STANDARD (inches)

Basic Part No.	Thread Size	A (Shank) Max.	Min. Sheet Thickness	C Max.	B1 Nom.	B2 Max.	D ± .010	E ± .005	F ± .015
570	#4-40	0.030	0.030	0.202	0.595	0.325	0.406	0.202	0.300
571	#4-40	0.038	0.040	0.202	0.595	0.325	0.406	0.202	0.300
572	#4-40	0.058	0.060	0.202	0.595	0.325	0.406	0.202	0.300
573	#6-32	0.030	0.030	0.218	0.595	0.325	0.438	0.202	0.300
574	#6-32	0.038	0.040	0.218	0.595	0.325	0.438	0.202	0.300
575	#6-32	0.058	0.060	0.218	0.595	0.325	0.438	0.202	0.300
576	#8-32	0.030	0.030	0.249	0.600	0.330	0.468	0.207	0.300
577	#8-32	0.038	0.040	0.249	0.600	0.330	0.468	0.207	0.300
578	#8-32	0.058	0.060	0.249	0.600	0.330	0.468	0.207	0.300
579	#10-32	0.030	0.030	0.311	0.605	0.335	0.530	0.220	0.300
580	#10-32	0.038	0.040	0.311	0.605	0.335	0.530	0.220	0.300
581	#10-32	0.058	0.060	0.311	0.605	0.335	0.530	0.220	0.300
582	1/4 - 20	0.058	0.060	0.374	0.675	0.385	0.625	0.242	0.350

METRIC (millimeters)

Basic Part No.	Thread Size	A (Shank) Max.	Min. Sheet Thickness	C Max.	B1 Nom.	B2 Max.	D ± .25	E ± .13	F ± .40
591	M3 x 0.5	0.97	1.00	5.48	15.11	8.26	10.31	5.13	7.62
592	M3 x 0.5	1.48	1.50	5.48	15.11	8.26	10.31	5.13	7.62
593	M4 x 0.7	0.97	1.00	6.38	15.24	8.38	11.89	5.26	7.62
594	M4 x 0.7	1.48	1.50	6.38	15.24	8.38	11.89	5.26	7.62
595	M5 x 0.8	0.97	1.00	7.98	15.37	8.51	13.46	5.59	7.62
596	M5 x 0.8	1.48	1.50	7.98	15.37	8.51	13.46	5.59	7.62
597	M6 x 1.0	1.48	1.50	9.48	17.15	9.78	15.88	6.12	8.89



ACCURATE
SCREW MACHINE
a Division of MW Industries, Inc.

Accurate Screw Machine

a Division of MW Industries, Inc.

Phone 877-285-2181 • Fax 973-244-9177 • www accuratescrew.com